

ALBIN PUMP AD

AIR OPERATED FLOATING DIAPHRAGM PUMPS

临台企业股份有限公司
PRELEAD INDUSTRIAL CO., LTD.



PRELEAD INDUSTRIAL CO., LTD.
PRELEAD 有限公司

SMALL GIANT

To come up with a really good product demands plenty of knowledge and fresh, innovative ideas.

Yet most important of all is to listen to our customers needs and requirements. So that we can see what can be improved and identify things that are not working optimally.

Only then can we create something new – and that actually makes a big difference for you, the customer.

NEW DESIGN, NEW FEATURES

The Swedish inventor Svante Bahrton developed the revolutionary AOFD (Air Operated Floating Diaphragm) pump that ALBIN PUMP today has the world patent on. The AOFD pump has many advantages that meet customers demands. The result of our efforts is a compact and flexible pump with attractive features.

COMPLETELY DIFFERENT AND A LOT BETTER

The ALBIN pump is designed for a large capacity and long service life. Compared to traditional AODD pumps, it offers 70% lower pulsation, 30-50% lower air consumption, noise reduction and 3–5 times longer operation time between service intervals. The compact outer measurements and capability to install the pump upside down, sideways or vertically means flexibility during installation and set up. What's more, it is designed so that all vital parts are easily accessible without having to remove the pump from the pipe system, greatly minimizing downtime. All these improvements result in lower operational costs, reduced cost for spare parts and improved overall economy.

AD

ALBIN PUMP AIR OPERATED DOUBLE DIAPHRAGM PUMP

SMART DESIGN

The ALBIN Pump is designed to meet your demands on high efficiency – and low costs for energy and maintenance.

The unique pump design gives low pulsations and therefore low vibrations and sound levels. The loads in the system are reduced, increasing the number of potential application areas. Thanks to a direct central flow, we have managed to minimize energy losses and air consumption. This, combined with its compact measurements and quiet, feathered flap valves, makes the pump particularly well suited for original equipment manufacturers (OEMs). Not least of all since it can be installed in any preferred position.

Yet the ALBIN pump is also a good choice for anyone who today has conventional AODD pumps. Loud, noisy and highly service demanding pumps can now be replaced with quiet and efficient ALBIN pumps – in virtually any application.

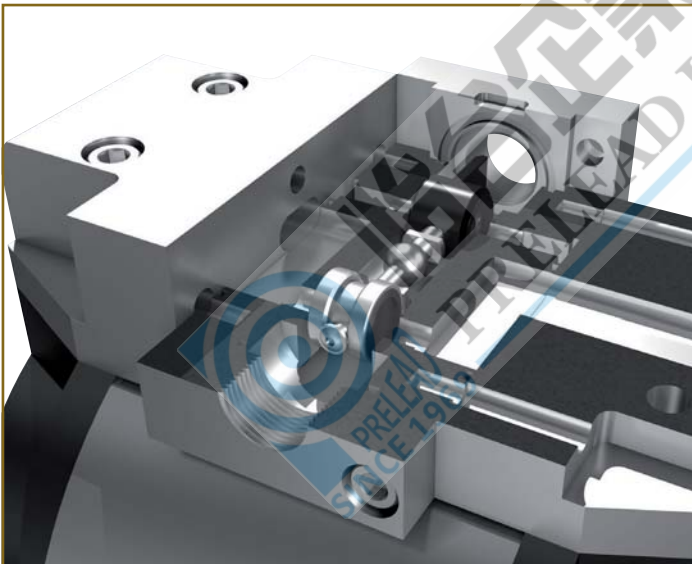

AIR VALVES / AIR MOTOR

The patented air valve at the heart of the drive system ensures very high operational reliability. The system including valve and air motor is self-cleaning, withstands oily, dry, humid or dirty compressed air and is insensitive to ice build-up. The technique enables rapid change and optimal control of the pump diaphragm, reducing pulsation.

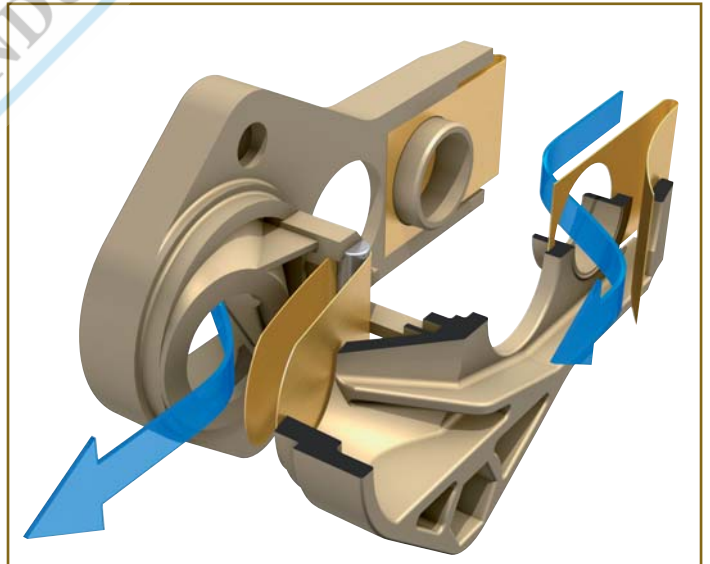

FLAP VALVE

An important innovation in the ALBIN pump is the feathered flap valves. They function regardless of how the pump is positioned – upside-down, sideways or vertically – ensuring maximal flexibility during installation. In addition, the valves are quiet and self-closing. This enables a longer service life and eliminates the problems with jammed ball valves.

ALBIN PUMP AIR OPERATED DOUBLE DIAPHRAGM PUMP

AD

- 70% lower pulsation
 - Lower energy consumption
 - Quiet and vibration free
 - Longer service intervals
 - Easier to install
-
- Longer service life *
 - Simpler maintenance *
 - Can run dry without damage *
 - Requires less space *

* compared to traditional diaphragm pumps.

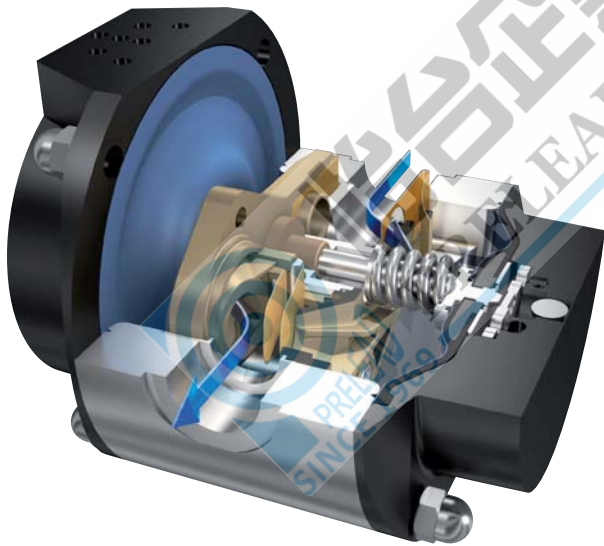

CENTRAL FLOW THROUGH FLEXIBLE DIAPHRAGM SUSPENSION

One of the secrets behind the pump's smooth operation is the patented FDS technology (Flexible Diaphragm Suspension). The diaphragms are not fixed at the shaft but can move independently of each other and work with soft, overlapping movements. This minimizes pulsations, increases time between services and enables a central flow.

ALBIN AD DESIGN

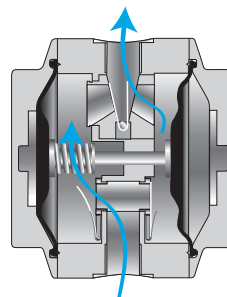

CONVENTIONAL DESIGN

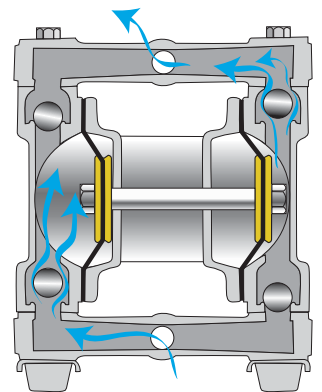

IMPROVED FUNCTION AND FLEXIBLE DESIGN

Instead of interrupting the flow of the fluid with many directional changes, it is pumped directly through the center of the pump. Current losses are reduced and the flow is more even and efficient. This also enables a more compact and flexible pump design.

AD**ALBIN PUMP
AIR OPERATED DOUBLE DIAPHRAGM PUMP**

UNCOMPLICATED WORLD LEADER

Advanced technology can actually be uncomplicated.

Our pumps feature smart solutions that make them better in a range of applications. The design means that maintenance and service can be performed quickly and cost-effectively since all parts are easily accessible - even when the pump is still connected in the pipe system. Take a look at the diaphragms, for example. They are easy to get at and therefore easily

replaced. In- and outtake valves, valve cage and shaft can be released by simply removing two screws. The air motor has internal mechanical connections to the pump unit and can be taken out and serviced without having to disassemble the fluid carrying parts of the pump. Even the heart of the air motor, the FPV (Frictionless Pivoting Valve) is easy to get at.

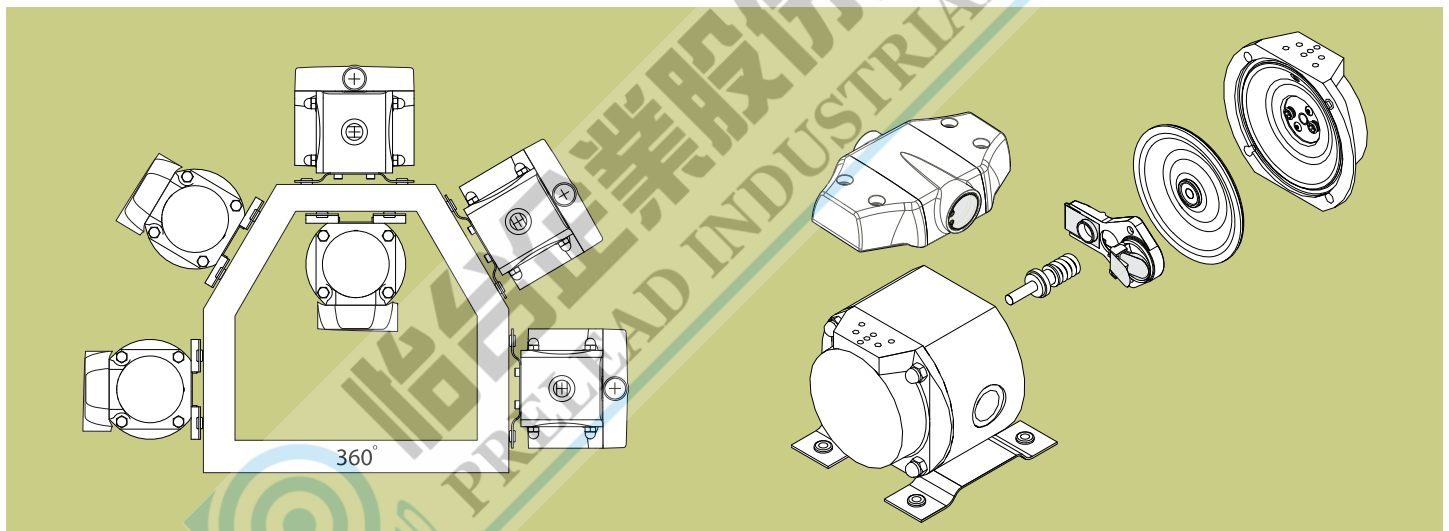

APPLICATION AREAS

Construction & General industry

Emptying of tanks, shaft and sample taking for analysis, diesel, paint

Aviation

Emptying/filling fuel, glycol, water

Paints & oils

Solvents, paint, preservatives, glue, varnish, stains, latex, acetone, turpentine, resin

Chemicals

Acids, alkalis, suspensions, stabilizers, solvents, glue

Cosmetics

Lotions, shampoo, liquid soap, soap emulsions, perfume, deodorants

Pharmaceuticals

Syrup, alcohol, glycerin, sweeteners

Manufacturing

Oil, coolants, degreasing wash, emulsions, waste oil

Water purification

Polymers, chemicals, sample taking for analysis

Paper

Printing ink, solvents, glue, resins, dispersion, latex

Petrochemical

Tank cleaning, oil spill, petroleum, petrol

Finishing/surface treatment

Galvanized wash, acids, lye, varnish

Marine

Waste water/bilge pumping

DIMENSIONS															
TYPE	A	B	D	E	F	G	H	I	J	K	L	M	N	O	Weight kg PP / AL
AD 15	14	145	2.5	64.5	130	97,6	141	101	118	147	147	123	1/4"	3/8"	2.5 / 3.7
AD 30	14	145	2.5	64.5	130	97,6	141	101	118	147	147	123	3/8"	3/8"	2.5 / 3.7
AD 60	14	164	2.5	74	149	97,6	141	101	118	147	147	141	3/4"	3/8"	3.6 / 4.9
AD 120	14	210	2.5	97	195	97,6	184	134	148.5	178	170	184	1.1/4"	3/8"	6.9 / 9.8
AD 400	See separate brochure / datasheet														

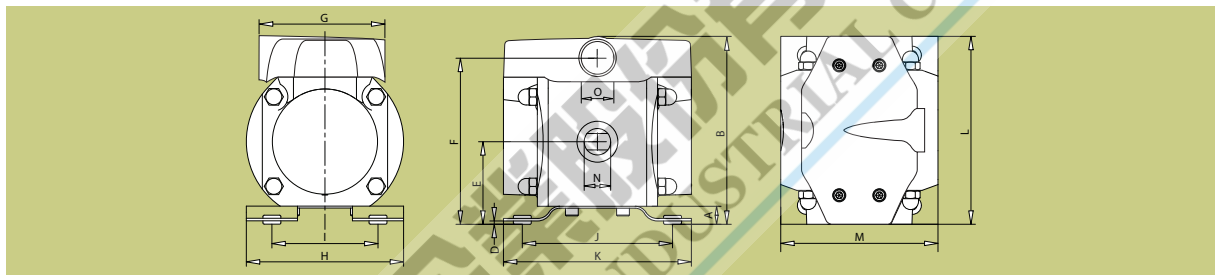

TECHNICAL DATA				
TYPE	AD 15	AD 30	AD 60	AD 120
Max Flow (l/min)	20	35	70	130
Max Pump pressure (bar)	7	7	7	7
Max Air pressure (bar)	7	7	7	7
MATERIAL				
Pump house	Polypropylene, Aluminium, Stainless Steel			
Diaphragms	PTFE (Standard), NBR, EPDM and other materials by request			

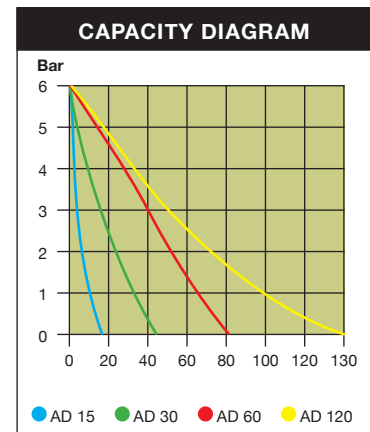

At ALBIN PUMP, we are committed to improving the production processes and competitiveness of our customers by enabling more effective operation and reduced maintenance costs.

All of our pumps are manufactured in France.

Visit our website and learn more today.

GB



◎ 聯絡我們

歡迎與怡台聯繫、協助您解決泵浦、鏈條、傳動設備之需求與問題

怡台企業股份有限公司

電話：(07)8153030 / (07)9709888

傳真：(07)8153080 / (07)9703900

地址：80673 高雄市前鎮區興化街135號

E-mail：sdmk1@prelead.com.tw